



OTM 03

User's manual - Use and Maintenance

Car radiator flush machines

E



Dear Customer, thank you for choosing a KAMMAK Radiator Cleaning Machine/Pump.

MANUAL

This manual is a safe guide for the use of the pump. Please read it carefully in all its parts before use.

This manual contains important information for the proper working and use of the equipment.

KAMMAK reserve the right to introduce any future changes without notice or replacement.

PRELIMINARY INSPECTION

Upon receipt of the pump, take it out from the carton and check it is in perfect condition. Also check that the data on the rating plate correspond to required ones. For any problem, immediately contact the supplier specifying the kind of fault.

In case of doubts about the safety of the machine, do not use it.

DESCRIPTION

The pump is fitted with built-in heater. Particularly recommended for difficult descaling treatments, they work in complete safety and autonomy enabling the operator to carry out other works at the same time.

Pump with tank for descaling radiators by using specific acid restoring products.

The pumps are equipped with special fittings and valves to adjust the flows and purge the sludge, built up by the operation, which is then rapidly removed.

Pumps are supplied ready to use, in strong carton boxes with related user's manual.

CONTENTS

1 - REGULATIONS – CE MARK	page	2
2 - THE ADVANTAGES OF THE MACHINE OTM-03	page	2
3 - TECHNICAL FEATURES	page	3
4 - CUSTOMER SERVICE	page	3
5 - USE	page	3
6 - SAFETY INSTRUCTIONS	page	4
7 - EXPLODED VIEWS	page	5
8 - DIRECTIONS FOR DISPOSAL	page	6
9 - WARRANTY TERMS AND AFTER-SALE ASSISTANCE CONDITIONS	page	6

1 - REGULATIONS – CE MARK

Declaration of Conformity

The pumps are in conformity with the following European Directives, Laws and Regulations:
Machinery Directive 2006/42/EC



QUALITY

KAMMAK equipments are manufactured with high-quality acid-resistant materials and submitted to severe operating tests.

Follow these instructions to avoid any operating and servicing problems.

2 - THE ADVANTAGES OF THE MACHINE OTM-03

Time and, above all, temperature increase make calcium salts, usually present in water, precipitate in the form of microcrystals and settle on metallic surfaces of pipes, radiators and cooling/heating systems, thus reducing flow rate and thermal efficiency.

To restore the original plant performance it is necessary to carry out a descaling with specific products and equipments.

With the **built-in heater device hot water** attacks scale on both sides, thus making descaling particularly effective and fast (as the normal dissolving action is combined with the detachment in flakes of scale, which is made friable by the double attack), even when pipes are almost totally obstructed.

RADIATOR/COOLING SYSTEM

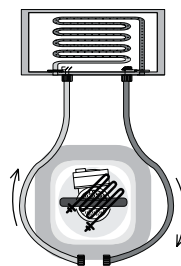

Thermo-Clean

3 - TECHNICAL FEATURES

OTM-03

Motor	650W - Hp 0,8
Max working pressure	4 Bar
Degree of protection	IPX4
Max. temperature	60 C
Flow rate	63* l/min.
Fittings	3/4"
Tank capacity	35 l
Heating coil	2000 w
Dimensions HxWxD	60 x 42 x 35 cm
Weight	Kg 22

* Data referred to the pump body outlet.

4 - CUSTOMER SERVICE

For enquiries on spare parts, please specify serial number of machine (shown on product and carton).

5 - USE

5.1 - HOW TO PREPARE THE MACHINE AND CHECK THE SEAL

- Fill the tank with enough water to ensure that the pump rotor housing is submerged during operation.
- Screw the outer ends of the flexible hoses securely to the radiator/heating-cooling system to be descaled.
- Connect the power cable to a single-phase 220 V power supply.
- Switch on the machine and check the seal of the hose fittings on the radiator and on the machine. In case of leaks of liquid, check hoses and fittings and replace the defective components, if necessary.
- When seal is safe, switch off the machine.
- If necessary, add more descaling product by referring to the dilution specified in the data sheet of the product.

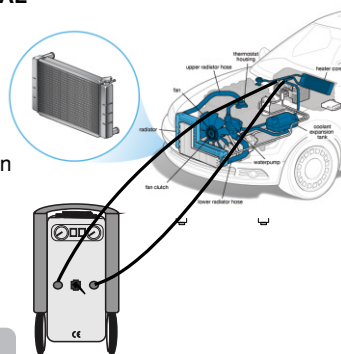

IMPORTANT!

- 1) Chemical cleaner should be mixed with fresh water to form a solution. Add 100 mL of chemical cleaner for 1 car. Do not use pure acid. It may harm pipes and installations.
- 2) Do not turn-on the HEATER when tank is empty. It may damage plastic tank.
- 3) Clean the FILTER after every operation.
- 4) After descaling operation REMOVE THE DESCALING LIQUID FROM THE TANK and wash out the pump by circulating clean water through it for at least 10 minutes.

5.2 - FUNCTIONING

Connect pump to the system.
Ensure that valve is in the closed position.

- Fill the tank with water.
- Add cleaning chemical to the tank. (Add 100ml chemical for each cleaning)
- Switch on the heater. Heat the water up to 50-60 °C in the tank.
- Switch-off the heater when temperature is 50-60 °C .
- Now switch on the pump and clean the system.
- Use flow reverser for efficient cleaning.

The OTM-03 has 1 x 250 cm Flow-Return Line and 1 x 250 cm Flow-Return Line hoses fitted with 3/4" brass hose connectors at the out board end and 3/4" fittings at the inboard end.
In cleaning process:

The inboard end of "Pressure Line Hose" should be screwed onto the corresponding " " brass nipples on rear of the hose support plate. The other end of this hose should be connected to the system inlet (radiator/boiler/pump).
The inboard end of "Return Line Hose" should be screwed onto the corresponding " " brass nipples on top of cap. The other end of this hose should be connected to the system outlet (radiator/boiler/pump).

In dumping process:

Disconnect one of the flow/return hose screwed on rear of the hose support plate and lead it to a toilet pan or drain pipe gully leading to a foul sewer.

5.3 - HOW TO CLEAN THE PUMP

After descaling REMOVE THE DESCALING LIQUID FROM THE TANK and wash out the pump by circulating clean water through it for at least 10 minutes.

6 - SAFETY INSTRUCTIONS

- Avoid using the pump in rooms where there are liquids, gases, flammable powders or with risk of explosion.
- Before plugging in the pump to the outlet, make sure the switch is off.
- The outlet must be suitable for the plug of the pump. Do not use non CE-marked defective outlets.
- Use (CE) approved extensions, only if necessary.
- Do not use plug adapter. Do not carry out any modifications to the plug nor to the electrical cable.
- Pump shall always kept in perfect efficiency.
- During maintenance operations, check the switch is off and the plug is not connected.
- All maintenance operations must be carried out by the authorized Technical Assistance Service.
- Only use KAMMAKOriginal spare parts.
- Do not carry out any modifications to the pump if not authorized by Technical Department (ask for written authorization).
- Keep children and unauthorized persons away from the pump.
- Keep the pump out of reach of children and unauthorized persons.
- Do not use the pump if tired or under the effect of alcohol, medicines or drugs.
- When using the pump, wear overalls, do not wear jewellery, keep hair away from the pump.
- When handling descaling liquids, be very careful. It is necessary to use Individual Protection Equipment (IPE).

Never run the pump without water!

7 - EXPLODED VIEWS AND SPARES DIAGRAMS

OTM-03

P.S...:For enquiries on spare parts,please specify always if needed for the model OTM-03.

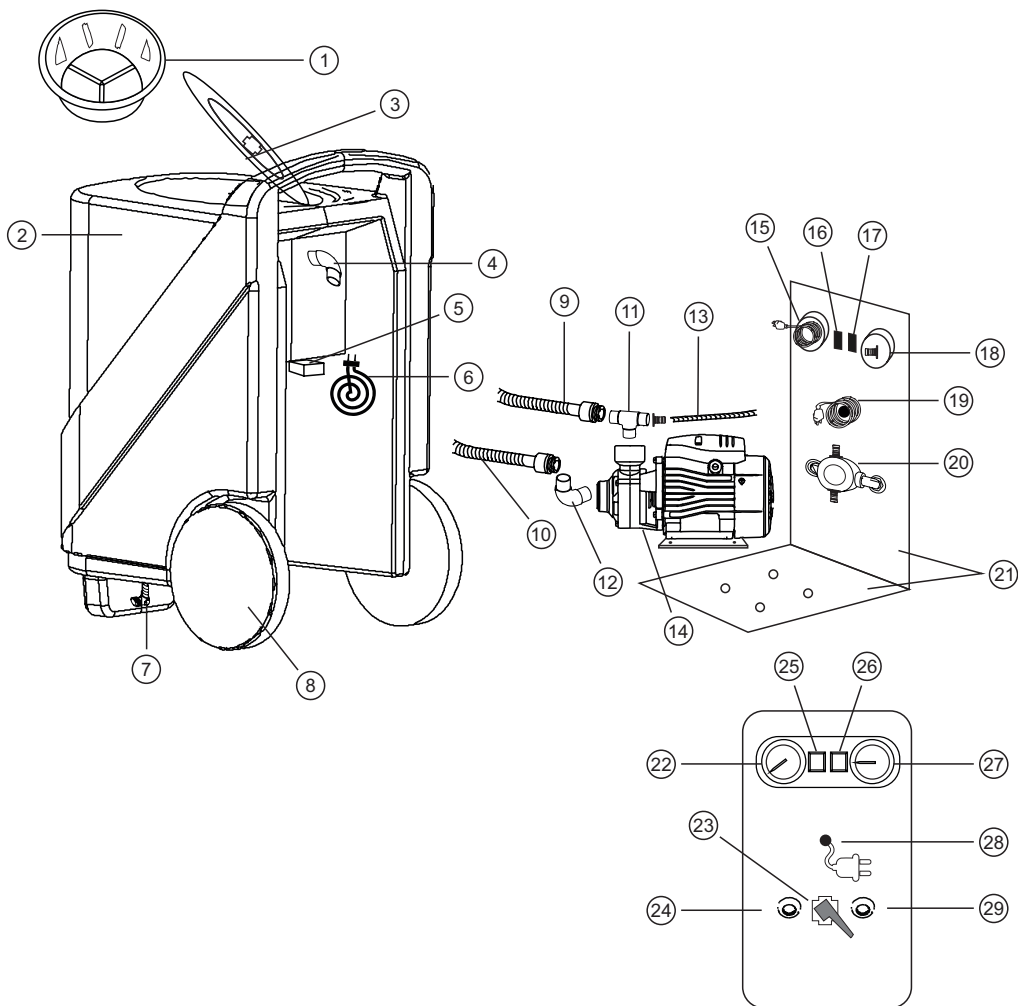

- | | | | |
|-------------------------|--------------------------|-----------------------------|-----------------------------|
| 1. Filter | 10. Connection hose 1/2" | 19. Electric cable | 28. Electric cable |
| 2. Tank | 11. 2 way connector 3/4" | 20. 4 way ball valve | 29. Flow-return outlet 3/4" |
| 3. Tank cap | 12. Elbow 3/4" | 21. Back&bottom metal panel | |
| 4. Elbow | 13. Pneumatic hose | 22. Pressure indicator | |
| 5. Thermostat | 14. Pump | 23. Flow reverser valve | |
| 6. Heating element | 15. Heat meter | 24. Flow-return outlet 3/4" | |
| 7. Elbow 1/2" | 16. Pump switch | 25. Pump on/off switch | |
| 8. Wheel | 17. Heater switch | 26. Heater on/ff switch | |
| 9. Connection hose 1/2" | 18. Pressure gauge | 27. Temperature indicator | |

8 - DIRECTIONS FOR DISPOSAL

In accordance with the WEEE directive 2002/96/EC on waste electrical and electronic equipment, the pump, when no longer used, shall be disposed of in a RAEE – WEEE collection centre authorized for disposal of waste electrical and electronic equipment, or directly contact your dealer.



9 - WARRANTY TERMS AND AFTER-SALE ASSISTANCE CONDITIONS

KAMMAK guarantee that the equipments sold are free from designing, manufacturing and material defects, under normal operating conditions and according to the directions contained in the instructions manual supplied with the equipment.

In compliance with the directive 1999/44/CE valid in the EEC countries, the warranty rights apply only to the purchaser.

KAMMAK, placed in Bursa - Turkey, guarantee the equipments against any conformity defects appearing within 12 (twelve) months from the purchase date, even when warranty operations have been carried out during this period, if only proved by a document.

The warranty covers all components of the equipment and provides for the repairing or, if necessary, the free replacement of those parts that, according to your Dealer, have conformity defects.

The warranty does not cover the aesthetic parts and the parts subject to wear and tear, nor does it cover all damages or failures whose cause is not due to the manufacturer, such as: transport, wrong installation or maintenance, tampering, sudden changes of electric voltage and/or hydraulic pressure, thunderbolts, corrosions, excess of humidity, accidental bumps or events beyond our control.

The warranty is valid only if the equipments have been installed, used and properly maintained according to all directions supplied by KAMMAK in the instructions manual attached to the equipment.

Should any conformity defects of the product be found during the warranty period, the Customer shall notify the Dealer to agree upon the terms of repairing and/or replacing of the product.



PRECAUTIONS

Only use "KAMMAK" chemicals in order to ensure good working and avoid damaging the equipments.

Once the lifetime of the pump has expired, do not dispose of it with household waste. The pump must be recycled in authorized centres and can be assimilated to a household appliance.



During handling lift the pump and do not drag it in order to avoid damages to the tank.

Temperature of the descaling solution must never exceed 60 C.

Flexible hoses and fittings can be damaged in time; make sure to check the seal whenever using the pump, as indicated in the pump preparation instructions.



Kammak Ltd.Şti, Bursa - Turkey
Phone:+90 2242232898
info@kammak.com.tr
www.kammakpumps.com